

North South University

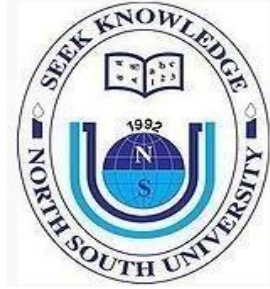

Department of Electrical and Computer Engineering
Senior Design Project Report
CSE/EEE/ETE499B

‘Speaking System for Mute and Deaf people’

Supervisor:

Dr. ATIQR RAHMAN

Associate Professor

Department of Electrical and Computer Engineering
North South University

Submitted by Group- 04

NAME	ID
Muhtasim Rafid Ahmed	1530194043
Fareeza Sharara karim Bohota	1631847645
Atik Mahmud	1711633042

Spring 2021

Declaration

This is to certify that this project is our original work. No part of this work has been submitted elsewhere partially or fully for the award of any other degree. Any material reproduced in this project has been properly acknowledged.

Name: Atik Mahmud

ID; 1711633042

Department of ECE

North South University

Name: Muhtasim Rafid Ahmed

ID: 1530194043

Department of ECE

North South University

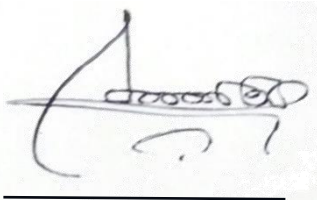

Signature



Signature

Name: Fareeza Sharara karim

ID: 1631847645

Department of ECE

North South University



Signature

Approval

The Senior Design project entitled “**Speaking System for Deaf and Mute People**” by

Atik Mahmud (1711633042)

Muhtasim Rafid Ahmed (1530194043)

Fareeza Sharara karim (1631847645)

has been accepted as satisfactory and approved for the degree of Bachelor of Science program in Spring-2021.

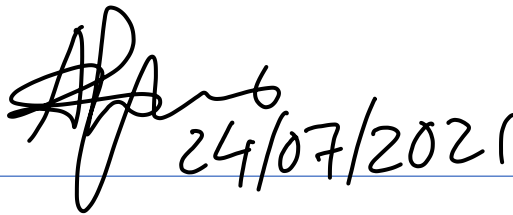

24/07/2021

Supervisor's Signature

Dr. ATIQUR RAHMAN

Associate Professor, Department of Electrical and Computer Engineering

North South University, Dhaka, Bangladesh.

Department Chairman's Signature

Dr. Mohammad Rezaul Bari

Professor and Chairman, Electrical and Computer Engineering

North South University, Dhaka, Bangladesh.

Acknowledgement

First of all, we wish to express our gratitude to the Almighty for giving us the strength to perform our responsibilities under the certain circumstances and complete the report. This project is very helpful for some special kinds of people in our society. This report has been designed to have a practical experience through the theoretical understanding. We also acknowledge our profound sense of gratitude to all the teachers who have been instrumental for providing us the technical knowledge and moral support to complete the project with full understanding.

It is imperative to show our appreciation and sincere great fulness for our honorable project supervisor **Dr. Atiqur Rahman** for his undivided attention and help to achieve this milestone. This project would have been implausible without his support and motivation. Also, our gratefulness is divine to the North South University, ECE department for providing us a course such as CSE/EEE/ETE 499 in which we could really work on this project and materialize it the way we have dreamt of. We consider ourselves as lucky for having chance to meet some wonderful persons.

We thank our friends and family for their moral support to carve out this project and always offer their support.

ABSTRACT

Deaf and mute communities are facing big problem for their disability. They are not comfortable with normal people. So, the aim of our project is to eradicate the barrier between disability and normal people in terms of communication. We have made a simple, wearable sensor-based project which is low cost and anyone can easily wear this. Our project is smart hand gloves and portable, and using flex sensor, amplifier, Arduinouno, Arduinolilypad, speaker, LCD screen, SD card. Through our project speaker can talk for mute and blind people and also deaf people can see the LCD screen. Standard ASL hand gesture taking as input database. ASL is standard sign language invented for mute and deaf people so that they are live their life as normal people. They also can work in different sector using our project. We did not use image processing or PIC microcontroller only because of high cost. We tried to make this project in low cost so that everyone can use this.

TABLE OF CONTENTS

<u>Section</u>	Chapters 1: Introduction	<u>Pages</u>
1.1	Chapter Focus	7
1.2	Motivation	7
1.3	Objectives	8
1.4	Report Outline	8
	Chapter 2: Literature Review	
2.1	Chapter Focus	9
2.2	Previous Works	9
2.3	Comparison	10
	Chapter 3: Technical Section	
3.1	Tools and Technologies	11
3.2	Description of Tools	13
	Chapter 4: Methodology and Experiment Setup	
4.1	Methodology	17
4.2	System Flowchart	17
4.3	ASL (American Sign language)	18
4.4	System Flow Chart	19
4.5	Experimental Setup	20
	Chapter 5: Conclusion	28

Chapter-1

INTRODUCTION

1.1 Chapter Focus

In this chapter we are going to describe how we used different languages to our project, how we are motivated to do this project and objective our project.

Basically, we developed a wearable hardware-based project which is for mute, deaf and disable people. We can insert standard ASL 30 sign language in our project or any other language according to the coding. When user wears our project gloves then he/she moves his/her hand according to sign then it is converting into English and Bangla language also through speaker. So, via our project they are able to talk like normal people. They will be able to live a normal life. They can share anything and the most important parts are medical and educational site. They can communicate with normal people. So that this project is working as helping hand for deaf and mute community.

1.2 Motivation

Our goal of doing this project is to support the deaf, mute and disable people. We saw their struggle in every sector and also in our family many of our relatives and friends who is facing problem for their disability. A little girl facing extreme problem in communication when she tried to communicate with other people. So, we realized that this is the huge problem for disable communities. Their struggle, their pain, motivated us to do this project. We think our project helps the disable communities and then they can easily communicate to normal people. Our target is to lessen the differentiation between normal and disable people.

1.3 Objectives and Contribution

Our main objective is social purpose and our target originally mute, deaf and blind people. We have used wearable gloves so easily anyone can wear those gloves. Our project is fully sensor based. Attached the flex sensor with the fingers of gloves. Motion of fingers hold by flex sensors, we did not use any bluetooth module as we made one hand project. We have used SD card slot to insert our database and Arduino UNO to convert the codes and speeches to the outputs. The whole system matches the motion with pre stored data and gives output through speaker and LCD display. Hand gesture converted into one language English but it is also possible to convert to Bangla, Hindi, French or any other languages around the globe. In whole world 9.1 billion people and in Bangladesh 7.1 percent are mute and deaf people. This device may help people.

Advantages:

1. Our project is low cost.
2. Easy to wear gloves.
3. Simple system.
4. Portable

1.4 Dissertation/Report Outline

In our report we discussed 5 chapters. 1st chapter (Introduction) consist of chapter focus, motivation, objective and contributions, report outline. 2nd chapter (Literature review) consist of chapter focus, earlier work, relationship/comparison between our project and earlier project. Chapter 3(Technical Sections) consists of description of tool and technologies. 4th chapter (Methodologies and Experiment setup) consists of chapter focus, methodology and experiment setup. Chapter 5 (Conclusion) consists of work summary.

Chapter-2

LITERATURE REVIEW

2.1 Chapter Focus

In this chapter we will talk about how people work with this type of project earlier. How we differentiate our project from earlier project. We will compare between our project and earlier project.

2.2 Earlier Works

A. In image processing research paper for implementation, they used to take pictures as input so web camera necessary. First of all, users have to create motion in front of camera then matches those motion with pre stored images. They are using PCA algorithm and that involves in two phases training phase and recognition phase. Training phase for gesture vector or gesture space purpose and recognition phase for sign recognize and Euclidian space purpose. In this

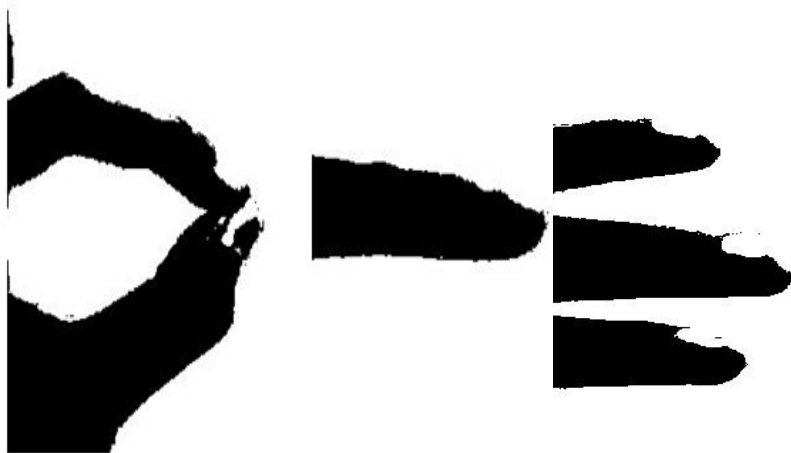

Fig: 2.1 Input Image Data

project they are using feature gesture for skin color, centroid, and sign recognition for identify the exact pre stored image. Pre-processing image formation by image acquisition, segmentation, and morphological filtering methods

B. “Hand gesture recognition and voice conversion system for dumb people”:

In this paper invented an artificial mouth which motion sensor-based project. Motion sensor placed in fingers of gloves. And database fed into PIC microcontroller. Motion sensor takes reading from gesture of fingers. PIC microcontroller matches the gesture with pre stored database. Specific sign gesture already stored in database. Using speaker and the output converted into English language and also text speech.

C. “Assisting System for Deaf and Mute Using ArduinoLilyypad and Accelerometer”

In this paper the project support to mute and deaf community to minimize their communication gap with normal people. RF transmitter, accelerometer, are placed in the gloves. Accelerometer set for to operate co-ordinates and sent data to Arduinolilyypad, RF receiver takes reading from RF transmitter and sent data to Arduino UNO for matching with pre stored data. LCD and speaker connected for output purpose. Arduino Uno is using for fabrication that makes the project shorter.

D. “Sign Language Recognition application for two-way communication deaf-mute”:

Communication is very important thing for everyone. Through communication anyone can express their feeling. But deaf and mute communities are suffering problem because of their disability. That’s why this paper invented Bluetooth gloves project where flex sensor using for finger and accelerometer for index finger. This project basically hand gesture converted into android application. Arduino Uno taking input from individual fingers and using mapping algorithm for minimizing complexity. This project sent notification to android application and people access all the information using speech to text conversion then change into gif animation.

E. “Sign Language Interpreter Using Smart Glove”

In the research paper proposed system explain that, they are taking input as hand gesture, facial expressions, body language and then converted into audio output. So, it is helpful for mute and deaf people communities.

F. “Smart Glove with Gesture Recognition Ability for the Hearing and Speech Impaired”

In this research paper invented smart gloves and they are using MATLAB or OCTAVE for accuracy for motion recognition and for mapping of the fingers they are using bend sensors, hall effect sensors and an accelerometer. Through this project deaf and mute people easily communicate with other people.

2.3 RELATIONSHIP/COMPARISON

Our project is fully sensor based, not image processing based. It is smart hand gloves, easy to wear and portable. We have used flex sensor, Arduinolilypad, Arduino UNO, amplifier, SD card slot in our project. Flex sensors for fingers motion and Arduinolilypad for matching the motion with database. We have created our own algorithm to initiate the project. Arduino UNO has been used to covert the codes into sign language and we have used amplifier to amplify the output from the Arduino to speaker. We have used an USB port by which we can input any kind of language to our device through memory card slot. Last but not the least our project is low cost, simple and helpful for physically disable person.

Chapter 3

TECHNICAL SECTIONS

3.1 TOOLS AND TECHNOLOGY:

The following hardware and software are used in this project:

1. LilyPadArduino family of boards- The ArduinoLilypad Main Board 328
2. Flex Sensors
3. Amplifier
4. SD card and SD CARD SLOT
5. LCD screen
6. Speaker Module
7. Gloves
8. Breadboard,
9. Wires, Clips, resistors, capacitors
10. Arduino UNO
11. 12V Lithium Ion battery and Buck Converter

For implementing the code, we have used Arduino software (IDE). Arduino (IDE) is an open source software and makes it easy to write code and upload it to the board. This runs on Windows, Mac OS X, and Linux. Code is written in C programming language and processing based.

3.2 Description of Tools and Technologies



Fig 3.1: Flex Sensor

Flex sensors connected with each finger in the gloves. We developed our project for one hand so that we need 5 flex sensors for 5 fingers. In this pic we saw that flex sensor has two pin and through this pin it is able to pass the data. Mainly we are taking fingers movement as input to use this flex sensor. Flex sensors pass the value of fingers motion.

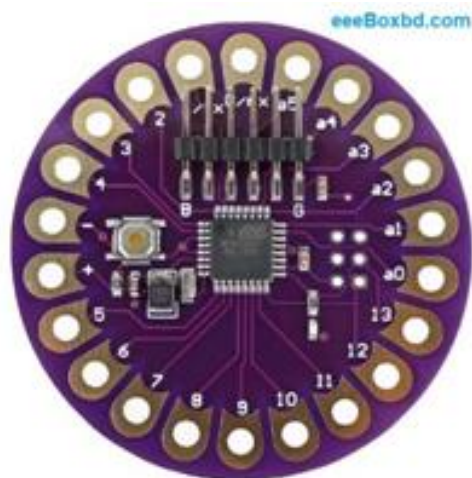

Fig 3.2: Ardino Lilypad

Arduino Lilypad has 5 pins which are connected with flex sensors. Five pins are connected with the flex sensor pin then flex sensor pass the data to Arduino lilypad. In Arduino lilypad we will store the standard ASL hand gesture data. When flex sensor data sent to Arduino lilypad then Arduino lilypad match the data with pre stored data. We attached Arduino lilypad with flex sensor via wire.



Fig 3.3: 12V Lithium Ion Battery

We have used a 12V Lithium ion rechargeable battery which is providing the power source of the device.



Fig 3.4: Aurdino Uno

Aurdino Uno: Arduino Uno has been used to convert the codes to ASL sign languages and is connected to the flex sensors and the battery.



Fig 3.5: Hand Designed Amplifier

Amplifier: We have designed an amplifier so that we can get the final output signal clear and strong via speaker. The amplifier will amplify the final output louder and clear.



Fig 3.6: Speaker Module

Speaker: we have used a 4watt speaker for the output signal.



Fig 3.7: Display

Display: 16:2 bit LCD Display was used.

Chapter 4

METHODOLOGY AND EXPERIMENTAL SETUP

4.1 Chapter Focus

As discussed in chapter 3 about the tools, in this chapter the application according to the method and experimental setup will be described. The following tools are used for the setup:

LilyPad Arduino family of boards- The Arduino Lilypad Main Board 328, Flex Sensors Speaker Module, Gloves, Arduino UNO is used instead FTDI chip, Wires, Clips and resistors. Mainly, the implementation of these tools are used in the methodology during the project set up.

4.2 Methodology (sensor based)

Since gloves are being used as the transfer medium for sign language, LilyPad Arduino family of boards are best for wearable applications. It works on rechargeable batteries and allows easy connection with sensors and actuators developed for an easy integration in clothes and fabrics. That is why Arduino Lilypad is used for performing the activity. Flex sensors are used to determine joint movement which is basically the ten fingers movement.

The Arduino Lilypad will store data of finger bending movement from flex sensors. Flex sensors are good at determining finger movements. The Arduino IDE will be used for implementing the code. It is an open-source Arduino Software (IDE) makes it easy to write code and upload it to the board. It runs on Windows, Mac OS X, and Linux. The environment is written in C programming and based on Processing and other open-source software. We have designed a memory card slot where we can use SD card and also use as USB port for the data transfer to the device or computer.

The main power source of this device is 12V lithium ion battery. After switching the power, 6V will be converted from 12V by buck converter to Arduino UNO. And Amplifier will use 6V from the battery for final output in the speaker by which we will be able to hear the sound or speech. The main purpose of the amplifier is to increase the amplitude of the signal and to

convert low frequency to high. We have used an OP AMP circuit to design the amplifier. Sign languages are conveyed by one hand but it can also be conveyed by two hands. One Hand (any one) will be the master controller where the data will be received and processed for the device. Hand gestures readings will be taken and recorded to create a sign language dictionary inside the Arduino which will be trained using a range of values. When the movements are made, the Arduino boards will communicate with each other by matching the gestures with the pre-stored data.

The flex sensors and arduino will be attached with the gloves that the mute and deaf people will wear in their both hands. The glove is easy to wear and can interpret basic sign language from the American Sign Language system.

4.3 ASL (American Sign Language)

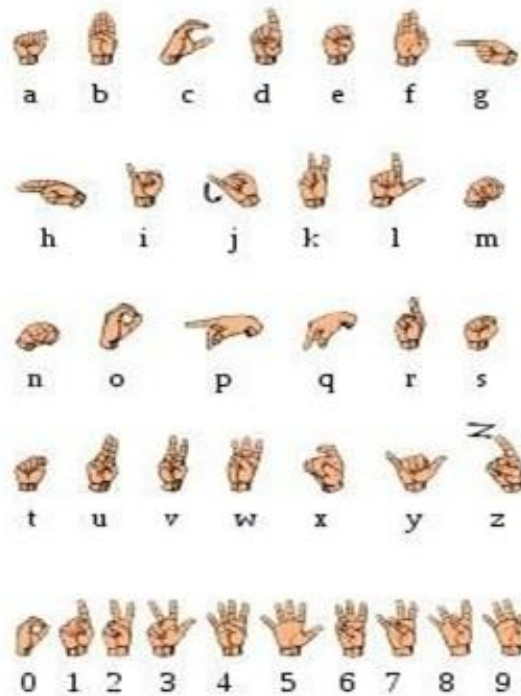

Fig: 4.1 (ASL)

American Sign Language (ASL) is a complete, natural language that has the same linguistic properties as spoken languages, with grammar that differs from English. ASL is expressed by movements of the hands and face. It is the primary language of many North Americans who are deaf and hard of hearing, and is used by many hearing people as well.

There is no universal sign language. Different sign languages are used in different countries or regions. For example, British Sign Language (BSL) is a different language from ASL, and Americans who know ASL may not understand BSL. Some countries adopt features of ASL in their sign languages.

So briefly it can be concluded that ASL has been used as the sign language in our methodology for the following basic reasons:

- A set of 26 signs of alphabets and different words
- World Wide used
- Common
- Easy to interpret

4.4 System Flow Chart

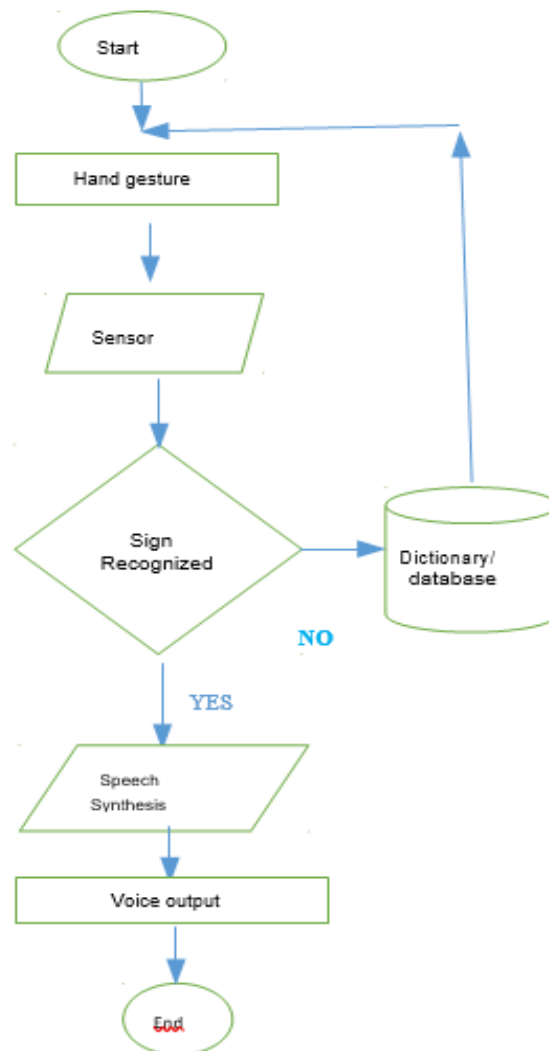

FIG 4.2 SYSTEM FLOWCHART

The above flow chart summarizes the methodology discussed above in 4.2.

4.5 Experimental Setup

Hardware Section

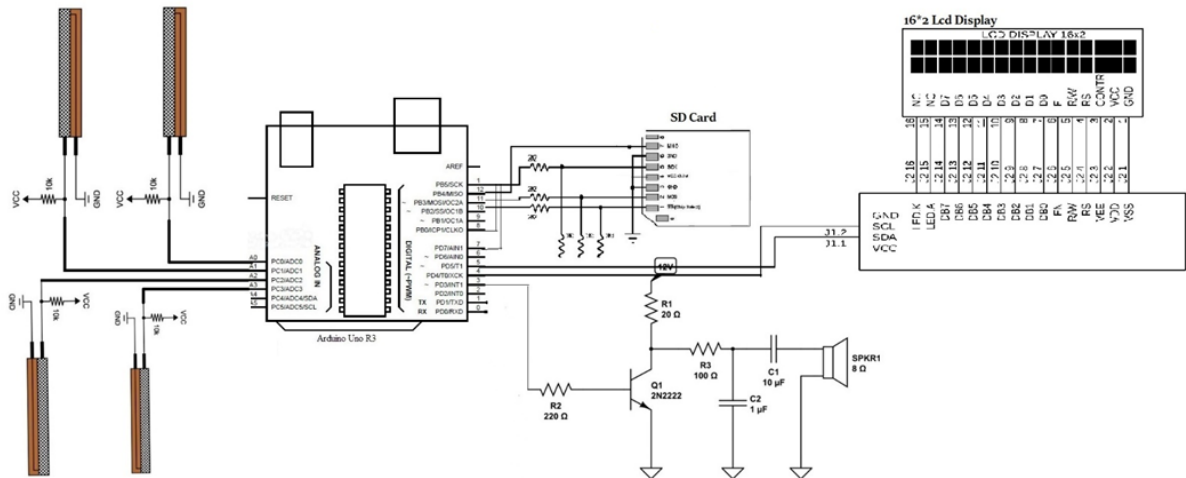

Fig: 4.3 Circuit Diagram

The circuit diagram mentioned above we used in our project. Our project will work according to this procedure. The pin diagram also shown here. From the left side there are four flex sensors which are connected with the analog pins of the Arduino .The amplifier, speaker module, Memory card slot and the LCD display are connected to the digital pins of the arduino.

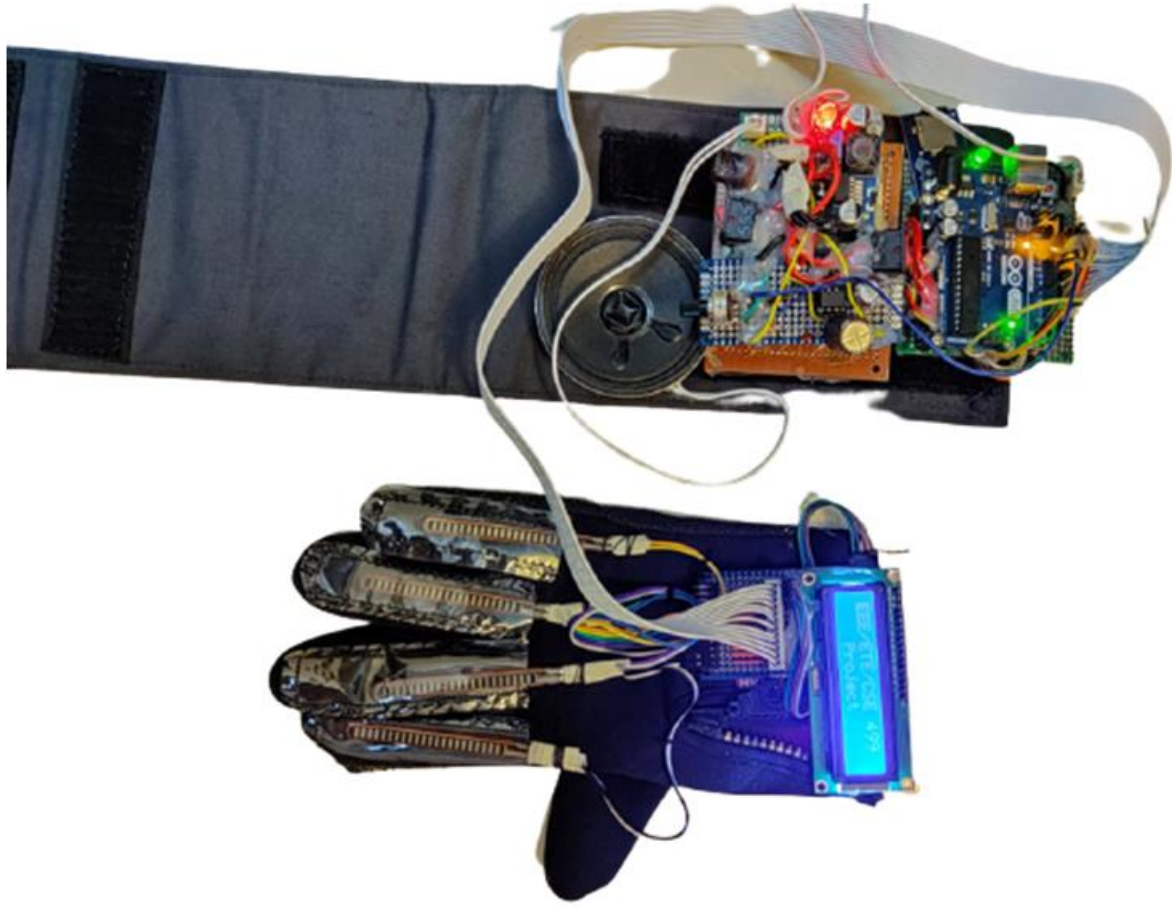

Fig: 4.4 Complete Hardware Setup

Here is the complete circuit setup including the gloves and Aurdino implementation. Both are connected with each other.

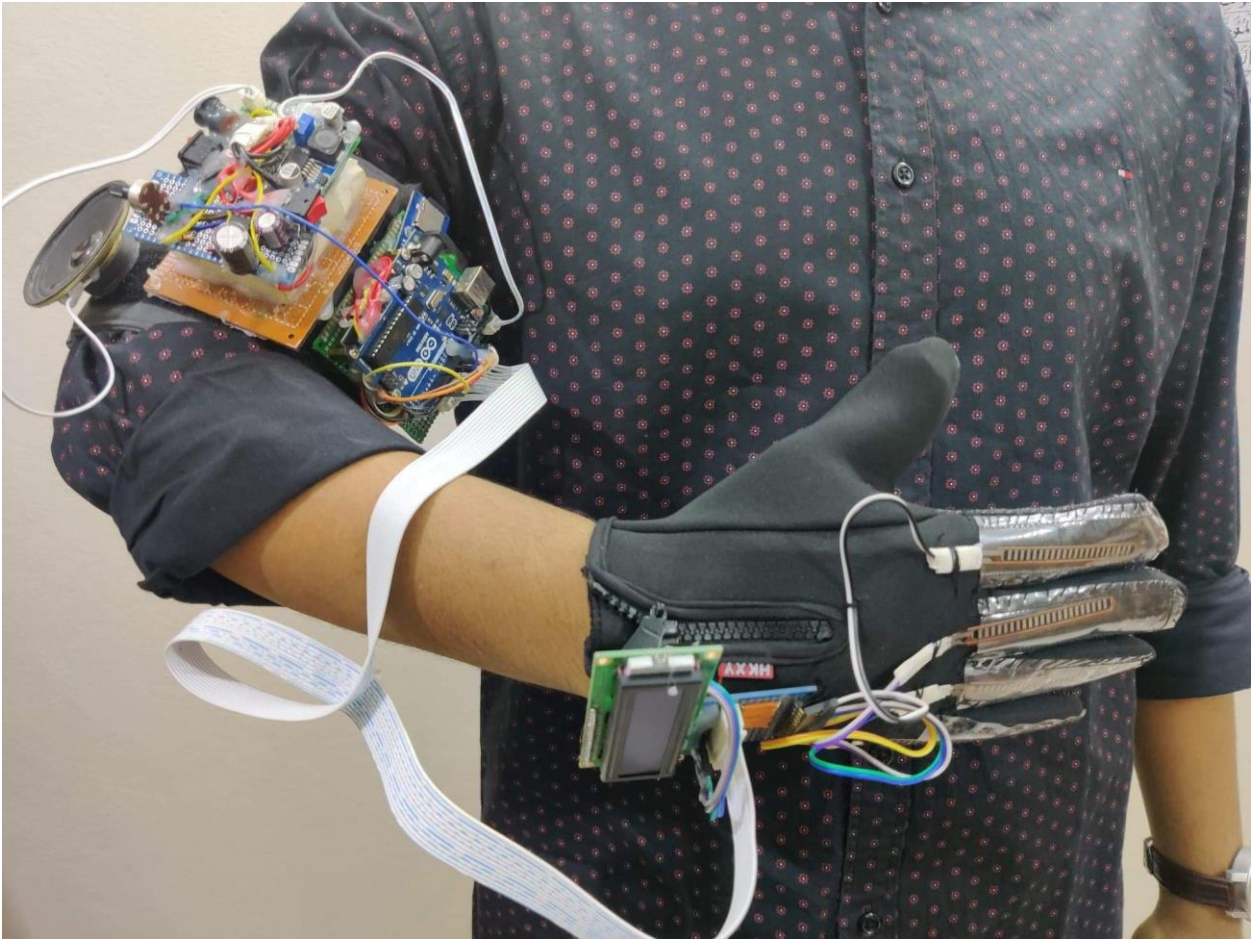

Fig:4.5 Project Ready for Implementation

This picture shows that one of our member wearing the glove in his hand.

Software Section

```
rafeed499handgesture | Arduino 1.6.9 Hourly Build 2016/04/20 08:33
File Edit Sketch Tools Help

rafeed499handgesture $
25 int count;
26 int voice_count=0;
27 void setup()
28     { Serial.begin(9600);
29       value1 = analogRead(flexPin1);
30       value2 = analogRead(flexPin2);
31       value3 = analogRead(flexPin3);
32       value4 = analogRead(flexPin4);
33
34
35
36       lcd.init();
37       lcd.backlight();
38       lcd.setCursor(0, 0);
39       lcd.print("Speaking System For");
40       lcd.setCursor(0, 1);
41       lcd.print("physically ");
42       delay(6000);
43       lcd.clear();
44       lcd.setCursor(0, 0);
45       lcd.print("Disable people");
46       delay(2000);
47       lcd.clear();
48       lcd.setCursor(0, 0);
49       lcd.print("EEE/EET/CSE 499");
50       lcd.setCursor(4, 1);
51       lcd.print("Project ");
52       delay(6000);
53       lcd.clear();
54       tmrpcm.speakerPin = 9;
55                                     //define speaker pin.
56       if (!SD.begin(SD_ChipSelectPin)) { //you must use pin 9 of the Arduino
57                                         //see if the card is present an
58       return;
59
60     }}
61
62 void loop()
63
```

Fig: 4.6 Code

In this part of code, we just collected the necessary library function. We initialized some values. We used delay function to show the messages with a little gap between two outputs.

```
Serial.print("/n3= ");

Serial.print(value3);
Serial.print("/n4= ");
Serial.print(value4);

delay(400);

if(value1>1890)//v3=790,v2=782,v1=908, v5=834 ,v4=
{
  lcd.clear();
  lcd.setCursor(0,0);
  lcd.print("Thank you ,Sir");
  I
  tmrpcm.setVolume(5);
  tmrpcm.play("2.wav");
  delay(2000);
}

if(value2>930) //v3=793,v2=886,v1=800, v5=834 ,v4=
{
  lcd.clear();
  lcd.setCursor(0,0);
  lcd.print("I Feel Bad,");
  lcd.setCursor(0,1);
  lcd.print("Need Help");
  tmrpcm
```

Fig: 4.7 Code

Here we checked the value with the default specified value. If condition is satisfied, then we printed our written message in the displays such as “Hello, I feel bad, need help” or Thank You.

Welcome

Text2Speech.org is a free online text-to-speech converter. Just enter your text, select one of the voices and download or listen to the resulting mp3 file. This service is free and you are allowed to use the speech files for any purpose, including commercial uses.

Text: Thank You , Sir

Max. number of allowed characters: 4000

Voice: Male US

Talking speed: Normal

Name of audio file: speech

Name of the resulting audio file without suffix.

Start

Fig: 4.8 Text Conversion

Here, we converted the sentences we set into audio speeches using this tool.

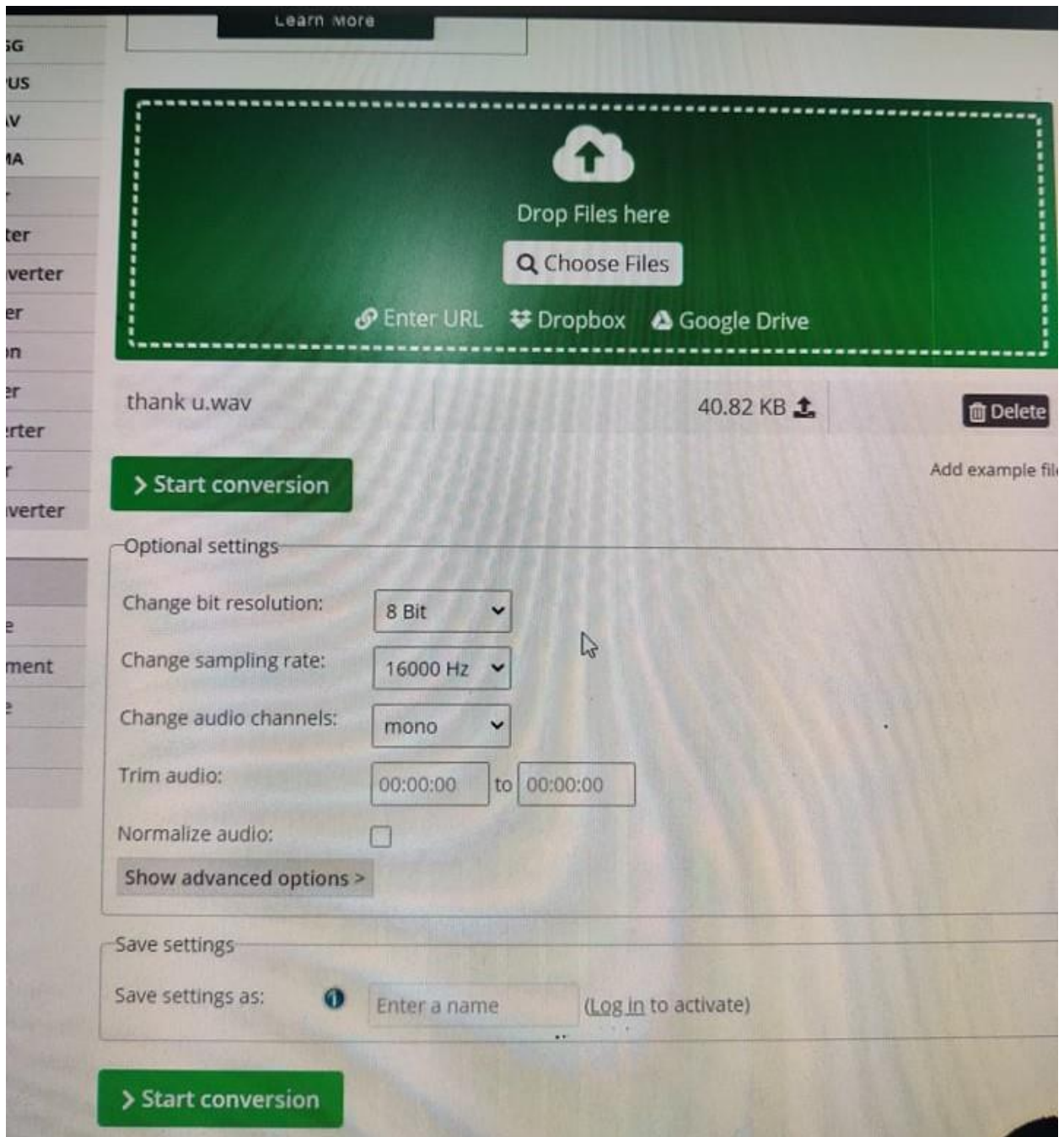

Fig: 4.9 Frequency

We used 8bit resolution and 16000 Hz frequency to generate our audio specces.



Fig: 4.10 Output

This is the LCD display which will show the message according to the hand gesture.

Chapter 5

Conclusion

The system is designed to facilitate a communication way of the deaf / mute people. Deaf people can easily communicate with normal people, easy to accomplish, easy to make change of sensor windows according to wearing in hand, portable designed and it produced an audio and visual output.

We tried to make the device portable so that movement can be easier and less complex. We have made the device for one hand only for low cost, but it can be easily implemented for both hands with help of Bluetooth module. Primarily we have used English speeches as codes for the output, but through the memory card any kind of language can be inserted and run for work purpose. We have kept options for all kinds of physically disable people, for instance people who cannot talk can use the speaker, people who can't hear can show what they want by the display. So this is how it's going to lessen the difficulties of people who are physically disabled.

However, the main goal of our project was to help and contribute to the welfare of the people. We tried our best to make and design this device as simple and low cost so that everyone can afford it. We hope the best outcome from this project.