

## SUSTAINABLE GREEN MARKETING: INCREASING AWARENESS OF RECYCLABLE ITEMS

*Mehe Zebunnesa Rahman<sup>1</sup>, Farhana Ferdousi<sup>2</sup>  
Shabnin Rahman Shorna<sup>3</sup>, Tanya Ahmed Chowdhury<sup>4</sup>*

### ABSTRACT

Managing waste has become a crucial issue in Bangladesh, especially at the advent of COVID 19 Pandemic. In Dhaka alone, approximately 6500 metric tons of waste are produced every day, with only 40% of this waste is correctly disposed of and managed. Bangladesh is aspiring to become a middle-income country within a few years, and waste management plays a vital role in ensuring that happens. The main objectives of this paper are to understand the nature of recyclable materials, the demand for these materials in the local market, business trends, and how to maintain sustainable economic growth through business. It also outlines the contribution of the informal recycling sector to the national economy and provides some policy recommendations regarding this sector. The study is aimed to assess recyclable eco-friendly product producers and build a green platform to combat global warming. This paper examined a method aligned with business principles that investigated whether this method would be effective and plausible in empowering those who are currently involved in waste management, and encouraging them to recycle and produce eco-friendly products, simultaneously encouraging sustainable development in the community, while also letting them earn a decent livelihood. This study utilized primary data through a questionnaire survey on 450 workers living in Bangladesh. The sample collections followed a purposive random sampling. The two latent exogenous constructs, namely training of recyclable items collections and attitude towards green marketing, are significant variables to achieve sustainable livelihood vis-à-vis economic growth.

**Key Words:** Recycling, Solid Waste Management, Sustainability

### INTRODUCTION

Bangladesh has the eighth largest population globally and is the twelfth most densely populated Dhaka, the capital city of Bangladesh, covers 347 sq km and has more than 15 million inhabitants. It is one of the fastest-growing megacities in the world. Inadequately planned, haphazard urbanization, along with industrial and commercial activities, contribute to the substantial quantity of waste produced in Bangladesh. Dhaka, the capital city of Bangladesh, had strong economic growth over the last two decades. It is one of the most densely populated urban areas in the world, at 19,447 people per square mile (BIDS 2020), with a total population of 16 million and a population growth of 6 percent per year. Urban solid waste management is considered one of the most critical environmental problems in developing countries, including Dhaka, Bangladesh. Improper solid waste management in these cities is impairing human health and causing economic, environmental and biological losses (Moghadam et al., 2009) and is rendering the local authorities of these cities a daunting task (Damghani et al., 2008). Solid waste pollution is a pollution

- 
1. Director, BBA Program and Associate Professor of Department of Management, School of Business and Economics, North South University, Bangladesh.
  2. Assistant Professor and Director, Institute of Research & Training (IRT) at Southeast University, Bangladesh.
  3. Senior Lecturer, Department of Management, North South University, Bangladesh.
  4. Lecturer, Department of Management, School of Business and Economics, North South University, Bangladesh.

produced and generated by human activities (Niessen in Wilson, 1977 and Tchobanoglous et.al, 1993). Solid waste is non-hazardous solid and semi-solid materials or non-liquid waste material arising from domestic, industrial, public services, agricultural, commercial and public street (Flintoff, 1976).

The first and foremost of these goals is to halve the proportion of people living on less than US\$1 per day, and those suffering from hunger, by 2015 (UN Millennium Declaration, 2000). Social enterprise is a new form of business entity, which not only operates a business but also pays attention to reducing society's major problems such as unemployment, malnutrition, poverty, education, environmental pollution, etc. through the means of business (Farhana, 2017).

Recycling follows innovative, effective, and systematic processes for used materials that could be further utilized as the raw materials for producing new products, in order to prevent and reduce waste and decrease potential environmental risks (Mehe et.al 2017). Nowadays, recycling is considered a key component of SWM. The objectives of this paper are to provide information on recyclers' socio-economic and socio-demographic characteristics and the benefits of their activities, and to identify their contribution to the national economy and promoting green marketing. Least developed countries (LDCs) are prone to suffer from the potential increase in natural disasters such as droughts and floods caused by climate changes. The LDCs have neither the adequate financial, institutional, and economic capability to manage the impacts of climate change nor the ability to re-develop their infrastructures if they are destroyed by natural disasters (Sokona & Denton, 2009).

Several factors affect the recycling activities and the productivity. Price of recyclable items, traders' behaviour, regulations, and diseases and infection have been observed. Thus, research is required to seek out the means to guide and educate the recyclers properly, covered the area of SWM being a formidable challenge in Bangladesh. These constructs are selected in light of prior research on the determinants of engagement in recycling and sustainability.

**H1:** There is a direct relationship between economic growth and training for recyclable items collections.

**H2:** There is a significant relationship between economic growth and attitude/awareness development towards green marketing.

## **LITERATURE REVIEW**

A critical issue associated with urbanization is solid waste generation. In rapidly urbanizing developing nations such as Bangladesh, the origin of the recycling industry is to some extent related to the origins of solid waste management. This problem has become more severe over the last few years, with the amount of solid waste generated in the cities being significantly higher than in rural areas. Recycling is a key factor, which is considered as a serious issue for reducing, re-using and managing everyday generated wastes in systematic manners. Recycling follows innovative, effective and systematic processes for used materials, which might further utilize as the raw materials for producing new products to prevent and reduce waste and decrease the potential environmental risks. Nowadays, recycling is considered as a key component of solid waste management, which is basically promoting three "R" - "Reduce, Reuse, and Recycle" of waste according to the hierarchy. Global warming and natural resource depletion are issues of international concern (Chen et al., 2018). To address them, the optimal usage of natural resources, is essential for simultaneously reducing environmental load and natural resource consumption in an economically feasible way. While the recycling of waste plastics and paper has been increasingly observed in several developing countries, they believe that there was much room for improvement.

Wilson et al (2015), has stated that thousands of people in developing country cities depend on recycling materials from waste for their livelihoods. Solid waste recycling practices in Bangladesh are mainly

dominated by the informal sector, and Afroze et al (2013) have shown that recycling income is playing an increasingly important role in the national economy of Bangladesh. In Japan, Chen et al., (2018) proposed a “smart recycling system” that uses existing industrial facilities that have high energy efficiency, for establishing a cost-effective and robust recycling system which would be particularly beneficial for high energy-intensive industries such as steel.

In the USA the green market counts about \$250 billion, with 63 million consumers directed towards products that either protect the environment contrary to the conventional ones, or have been produced with processes that respect the society and the environment. The same consumers are prone to spend an additional 7-20% in order to buy pure green products and reject the non-viable alternatives offered to them by the conventional market (Reitman 1992, Papadopoulos et al. 2012).

While improvements for waste management infrastructure in developing countries do not receive as much attention as healthcare infrastructure or structural reform in educational infrastructure, there are several reasons why improving waste management is a priority in developing countries such as Bangladesh. (Malhotra, 2020) A number of negative consequences exist due to current waste management practices in countries, from improper waste disposal leading to marine pollution. Consequently, in nations such as Bangladesh, proper waste disposal and recycling is of the utmost importance to ensure the optimal usage of the limited resources available. Waste workers in Bangladesh in particular, need this support; currently, most of them can barely earn a proper livelihood, due to there not being enough infrastructural facilities and implementation. The importance of recyclable items to underprivileged workers below the poverty line cannot be emphasized enough; recycling can increase the lifespan of products that are used, and can curb increases in waste generation and reduce the energy required to process the waste.

One such way of increasing the production and recycling of eco-friendly products is to support and invest in the creation of social businesses; A social business is a business that pays no dividends. It sells products at prices that make it self-sustaining. The owners of the company can get back the amount they have invested in the company over a period of time, but no profit is paid to investors in the form of dividends. Instead, any profit made stays in the business to finance expansion, to create new products or services, and to do more good for the world (Yunus, 2007).

Chen et al., (2018) investigates the business models of two waste recycling companies in Thailand and Taiwan. First, the basic micro and macro environmental factors were analyzed, including the period of firm’s business operations, location of the firm, space for separating and storing recyclable waste and various types of recyclable waste purchasing affecting the firms’ performance in these two economies. Second, different recyclable waste materials, volumes and price strategies between the case companies were compared. Third, this study also investigates the impacts of factors regarding resource characteristics, a firm’s capabilities and an entrepreneur’s abilities to improve a firm’s performance all compose a critical business model. The results showed that there were an increasing number of owners of waste recycling businesses developing and adapting to new business models. Detailed comparisons are reported and discussed in the article to shed light on managerial and policy implications (Chen et al., 2018).

## **THEORETICAL FRAMEWORK: CONSTRUCTS FOR THEORETICAL FRAMEWORK OF STRUCTURAL EQUATION MODEL**

The following constructs have been considered in the research. All constructs are relevant to the study based on literature and social context.

This study presents a framework to analyse and consider the nature and functions of different factors and to examine the relationship between these factors. The framework identifies two basic factors which

facilitate the efforts of the low-income group to build their livelihood assets. They include such things training for small business development with recyclable items and awareness towards green marketing. Therefore, based on the theoretical linkages between economic growth and factors, this study developed the following workable framework (Figure no 1). A list of variables from the literatures as well as from the field was used to facilitate the analysis.

Based on the comprehensive literature reviewd this study presented the relationship between economic growth and different affecting factors.

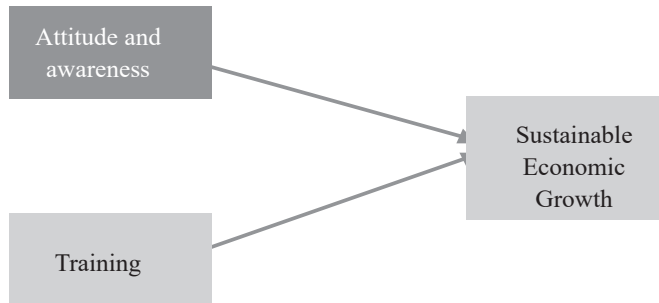

Figure 1: Theoretical Model

## MATERIALS AND METHODS

SEM is a class of multivariate techniques that combine aspects of factor analysis and regression, enabling the researchers to simultaneously examine relationships among latent constructs (Zinuddin 2015). SEM is one of the most prominent statistical analysis techniques. Particular interest is on the question whether some of the factors, namely training and awareness actively play a role in sustainable economic growth. This issue is particularly significant since it has been addressed in the various relevant literature. There is potential for the recycling sector to play an important role in alleviating poverty of the waste workers and contributing in economic growth.

## STUDY AREA, SURVEY DESIGN AND SAMPLING METHOD

This research provides the empirical evidence for answering this question by estimating a Structural Equation Model (SEM) using primary data gathered within Dhaka, the capital city of Bangladesh. Structural Equation Modeling (SEM) is among the most advanced statistical analysis techniques that emerged in recent decades. The theoretical framework shows the dependent construct is sustainable growth of economy, and the independent constructs are a training for recyclable items collections and selling and awareness development towards green marketing .

This study employed self-administered questionnaires for data collection. The structured questionnaire and stratified random sampling were designed to measure all constructs involved in the theoretical framework. A total of 450 respondents were selected from two urban areas in Dhaka city ,namely Dhaka North City and Dhaka South City . It is to be mentioned that Dhaka city has been divided into two administrative corporations, namely Dhaka North City Corporation (DNCC) and Dhaka South City Corporation (DSCC)

under the



Figure 2: Map of The Study Area

One of the study areas is the largest government-approved sanitary landfill located at Matuail in DSCC. with another located in DNCC. These areas are chosen based on the availability of waste workers and recyclers. There were three possible methods for the survey: face-to-face interview, telephone interview, mail and google form. Among these methods, this study chose face-to-face interviews and mobile phone conversation because the quality of the data obtained by this method has been found to be the most complete, comprehensive, and meaningful. All the responses were measured on a 10-point “Likert” scale with 1 = Strongly Disagree and 10 = Strongly Agree. Structural Equation Modeling (SEM) is the second generation statistical method widely employed by researchers nowadays to analyze the interrelationships

among variables simultaneously in a model. The general SEM model is composed of two sub-models: a measurement model and a structural model. The most popular estimation technique for SEM, which is the Maximum Likelihood (ML) estimation, uses the assumption that the following conditions are addressed: i) the sample is very large; ii) the distribution of the observed variables' multivariate is normal; iii) the hypothesized model is valid; and iv) the scale of the observed variables is continuous. The study's data were verified to address these conditions; as such the ML method was utilized to estimate the model and the parameters. The Confirmatory Factor Analysis (CFA) is a specialized form of factor analysis. It is used to examine if the measurements of a construct are consistent with the researcher's comprehension of the construct's nature. The identified and selected items were analyzed to decide if they converge to the domains to which they were specified. Factors with Eigenvalues of more than one are regarded as significant and utilized for further analysis in this study. suggested that items with factor loadings of at least 0.50 are significant. The number of scale points in the questionnaires has been an area of much debate. Out of the 450 questionnaires 400 were completed and used for analysis where (74%) were male and (26%) were female. Most of the respondents hold a non professional degree while the rest have primary degree. A majority of them have experience above 3 years.

As suggested by four decision criteria were used in evaluating the results generated from measurement models: internal consistency (composite reliability), indicator reliability, convergent validity (average variance extracted-AVE) and discriminant validity. Convergent validity was assessed based on factor loading, composite reliability, and variance extracted.

The factor loading for all items in this study exceeded the recommended level of 0.6. Root Mean Square Error Approximation (RMSEA) values less than 0.08 indicate good fit. The values larger than 0.10 are indicative of a poor fit. RMSEA values ranging from 0.05 to 0.08 indicate fair fit. The values ranging from 0.08 to 0.10 are indicative of mediocre fit. This research has received .07 RMSEA which indicates very good fit.. Composite reliability which depicts the degree to which the construct indicators indicate the latent construct ranged from 0.770 to 0.875, exceeding the recommended level of 0.7 which was suggested by. In the data mining process, all skewness values lie between -1.0 and 1.0, and is considered normally distributed and acceptable to proceed with the parametric analysis procedure. Zainudin (2015) suggested Kaiser-Meyer-Oikin (KMO) measure of sampling adequacy if the seven variables is close to 1.0. These KMO values exceed the recommended value of 0.6 and this suggests that the data is appropriate to proceed with data reduction procedure (Table 1).

As indicated in the analysis section, the results of this study were generated and confirmed at two successive stages, a) Pilot test and b) field survey. Exploratory factor analysis (EFA) is recommended for use in pilot study whereas Confirmatory factor analysis(CFA) is use in final field surveys. The values of composite reliability for all constructs were above 0.80 which are sufficiently higher than the threshold value (0.60). The AVE values were also satisfactory, as they exceed the minimum accepted level of 0.50 for all constructs in measurement mode.

**Table 1: Fitness Index**

Name of category	Name of index	Index full name	Literature	Level of acceptance	comments
1. Absolute fit	Chi-square	Discrepancy chi square	Wheaton et.al (1977)	$P > 0.05$	Sensitive to sample size $>200$
	RMSEA	Root Mean Square of Error Approximation	Browne and Sorbom ( 1984)	$RMSEA < 0.08$	Range 0.05 to .1 acceptable
	GFI	Goodness of Fit Index	Joreskog and Sorbom (1984)	$GFI > 0.90$	GFI= 0.95 is a good fit
2. Incremental fit	AGFI	Adjusted Goodness of Fit	Tanaka and Huba(1985)	$AGFI > 0.90$	AGFI= 0.95 is a good fit
	CFI	Comparative Fit Index	Bentler (1990)	$CFI > 0.90$	CFI= 0.95 is a good fit
	TLI	Tucker-Lewis Index	Bentler and Bonett91980)	$TLI > 0.90$	TLI= 0.95 is a good fit
	NFI	Normed Fit Index	Bollen (1989b)	$NFI > 0.90$	NFI=0.95 is a good fit
3. Parsimonious fit	Chisq/df	Chi Square / Degree of Freedom	Marsh and Hocevar(1985)	$Chi\ square/df < 5.0$	The value should be less than 5.0

Source: \*\*\* one could ignore the absolute fit index of minimum discrepancy chi-square if the sample size obtained for the study is greater than 200 ( Hair et al 1996, Joreskog and Sorbom , 1996) (Zainudin 2015)

**Table 2: Cronbach and Items with Variable**

Variables	No of items	Cronbach
Training	5	.788
Economic growth	5	.744
Attitude	5	.854

Structural Equation Modelling (SEM)

Structural Equation Modelling using AMOS 22.0 confirmed two significant findings

1. There is a direct relationship between economic growth and training for recyclable items collections
2. There is a significant relationship between economic growth and awareness development towards green marketing

Finally, Structural equation modeling (SEM) has been placed with latent variables, training for recyclable item collections and attitude towards green marketing dependent variable is achieving sustainable livelihood (SLV) along with economic growth (growth of economy). Results showed that the training, (motivation to do work properly) and attitude were positively significant (table no 3)

**Reliability Test**

Reliability level for each variable was determined using Cronbach’s Alpha. The alpha value for each variable exceeded 0.7 and this is considered acceptable for further analysis. Correlation test was conducted to test the correlation of each independent variable (namely training and attitude) with sustainable livelihood. Two variables with the highest correlation value are training and attitude are (0.56), which is <0.85.(Fig 2). This indicates that there is no multicollinearity problem. Thus, this research decided to focus on these variables for further analysis.

SEM is a confirmatory method providing a comprehensive means for validating the measurement model of latent constructs. The validating procedure is called Confirmatory Factor Analysis (CFA) The CFA method has the ability to assess the Unidimensionality, Validity and Reliability of a latent construct. The researcher could run the CFA for every measurement mode, allowing them to confirm the unidimensionality, validity and reliability for the all constructs involved before modelling their inter relationship in a structural model.

Systematic training happens to be an important element in many successful waste management systems that facilitate efficient financial management through minimum energy and labour inputs in the downstream process. Municipal waste, given its diverse sources, will contain a combination of materials. Nevertheless, of late, it has been observed that recyclables with economic value such as waste paper, plastic, broken glass, metal, etc., are not segregated and are thrown out on the streets by people along with domestic/trade/ institutional waste.

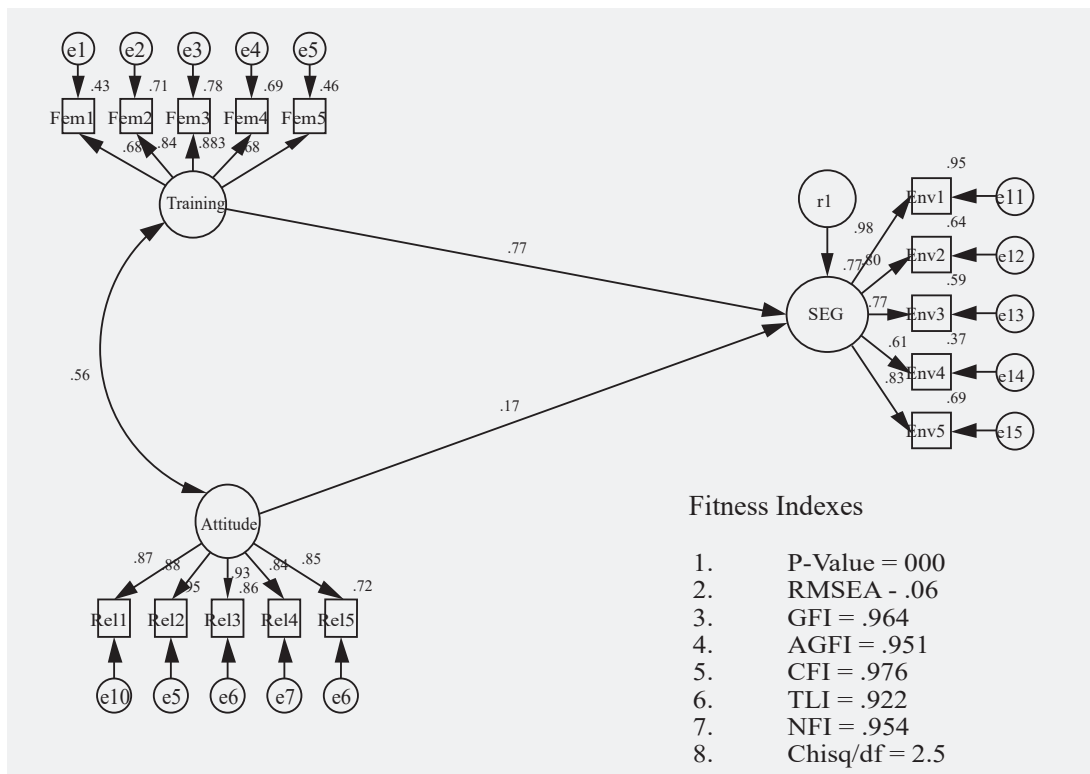

Figure 2: The graphical representation of structural equation model (SEM)

**Table 3 : Rule of Thumb**

Name of category	Name of Index	Level of acceptance	Comments
1. Absolute fit	Chisq	p> .05	Sensitive to sample size >200
	RMSEA	RMSEA<.08	Range .05 to .1 is acceptable
	GFI	GFI>.90	GFI=.95 is a good fit
2.Incremental fit	AGFI	AGFI> .90	AGFI=.95 is a good fit
	CFI	CFI> .90	CFI=.95 is a good fit
	TLI	TLI> .90	TLI=.95 is a good fit
	NFI	NFI> .90	NFI=.95 is a good fit
3. Parsimonious fit	Chis W	Chi/df< 5	The value should be less than 5

Source: (Zainudin 2015)

**Table 4: Regression Weight**

Items	Estimate	S.E.	C.R.	P	Result
Sustainable economic growth (economic ← Training)	0.77	0.062	12.4	***	Significant
Sustainable economic growth (economic ← Attitude)	.17	.061	2.78	***	Significant

### ***The goodness of fit index***

The result showed that the GFI of the model is 0.964 in Table 3. It shows the model is acceptable based on however the structural model fits the observed data, since the value of the Normed Chi square (CMIN/DF) was 2.5, the recommended value by the statistician is below 5 is acceptable and good fit. Similarly other fit indices showed good indicators for the revised model (CFI= 0.971 and RMSEA = .06) and following the table by scholars (table rule of thumb) (Bryne, 2010) and (Hair, 2010). Normed fit index (NFI) = 0.954 and TLI=0.912 on Table 3. For the incremental fit measures, Comparative fit index (CFI), Normed fit index (NFI), and Incremental fit index (IFI) were performed well. The values of these met the recommended Root mean square effort of approximation (RMSEA) were adequate value.

### ***Training and sustainable livelihood***

The  $\beta$  value of 0.77 in table 4 between training for recyclable items and sustainable economic growth indicates that training as an important factor affecting their satisfaction level. Thus, the study agrees that training program has a significant impact on sustainable economic growth.

### ***Attitude and sustainable livelihood***

The  $\beta$  value of 0.17 in table 4 between attitude towards green marketing and sustainable economic growth indicates that attitude towards eco friendly as an important factor affecting their satisfaction level. Thus, the study agrees that attitude has a significant impact on sustainable economic growth.

### **CONCLUSION AND RECOMMENDATION**

From the aforementioned investigation that was conducted, we were able to find that an increase in recycling will lead to an increase in income and sustainability of livelihoods for waste workers and others involved in recycling. However, the provision of special training is required for efficiency in every stage of waste management. Providing the necessary training to this underprivileged group, and will help in poverty reduction. Providing the “Social Business Fund” decreases poverty (Ferdousi. F., 2018). This would help alleviate the lack of credit which is faced by many small recycling workers, who cannot produce high-quality products due to scarce technical resources- various fund will aid in employment creation and encouraging enterprise. This will help fulfill one of the primary objectives of every social business-mitigating a societal problem successfully. Furthermore, with this support, there will be an increase in production of eco-friendly products by those involved in recycling, which would go a long way in reducing carbon emissions For these reasons, our recommendation is to provide training, loans and infrastructural support, while also increasing public awareness about the necessity of such initiatives. Poverty alleviation and economic growth have been some of the main agendas for development in most developing countries. The findings of this study imply that industrialization with the formal sector, will have a positive impact on efforts of the nation to reduce poverty and obtain economic growth. Hence, the study’s findings suggest that participation of the Waste Pickers in non-waste picking activities does not necessarily reduce their likelihood of being poor. The findings of our study support the view that planned, monitored, and supported waste picking activities can be a viable option for reducing poverty among the urban poor. Organizing and training informal recyclers in Municipal Solid Waste Enterprises (MSWE) was a very effective way to upgrade their ability and add value to the materials collected. Health awareness, hygiene, and nutrition intake by the respondents vary based on a person’s attitude, behaviour, and food habit. In addition, several essential variables were found to be insignificant with unexpected results, but further investigation was not carried out given the scope of this study. In Bangladesh at present, there is a lack of a comprehensive research on SWM, particularly from the economic point of view. This study aims to assess the current status of waste management and to focus on how it helps to reduce poverty among waste workers/recyclers, as well seeking to provide some economic analyses regarding solid waste management focussing on the potential benefits from SWM.

### **REFERENCES**

- Afroz, R., Hanaki, K., Tuddin, R., & Ayup, K. (2010). A survey of recycling behaviour in households in Dhaka, Bangladesh. *Waste Management & Research*, 28(6), 552–560. <https://doi.org/10.1177/0734242X09353434>
- Byrne, B.M. (2010) Structural Equation Modeling With AMOS: Basic Concepts, Applications, and Programming 2nd Ed. Routledge. New York.
- Chen, X., Tai, C.-T., Wu, L., Tsai, F.-S., & Srimanus, K. (2018). Business Models for Social Innovation of Municipal Solid Waste Recycling Companies: Comparison of Two Business Cases in Thailand

- and Taiwan. *Sustainability*, 10(4), 1009. MDPI AG. Retrieved from <http://dx.doi.org/10.3390/su10041009>
- Damghani, A. M., Savarypour, G., Zand, E., & Deihimfard, R. (2008). Municipal solid waste management in Tehran: Current practices, opportunities and challenges. *Waste management*, 28(5), 929-934.
- Ferdousi, F. (2017). Understanding consumer behavior toward social enterprise products. In *Consumer Behavior-Practice Oriented Perspectives*. IntechOpen.
- Ferdousi, F., & Mahmud, P. (2018). Investment in microenterprises for scaling up business growth: evidence from social business project. In L. Mura (Ed.), *Entrepreneurship-Development Tendencies and Empirical Approach*. IntechOpen.
- Flintoff, F. (1976). *Management of solid wastes in developing countries*. New Delhi: World Health Organization.
- Fujii, M., Fujita, T., Chen, X., Ohnishi, S., & Yamaguchi, N. (2012). Smart recycling of organic solid wastes in an environmentally sustainable society. *Resources, Conservation and Recycling*, 63, 1-8. <https://doi.org/10.1016/j.resconrec.2012.03.002>.
- J. F. Hair, W. C. Black, B. J. Babin and R. E. Anderson (2010) "Multivariate Data Analysis," Upper Saddle River: Prentice-Hall.
- Malhotra, M. (2020, June 17). *Developing countries need new solutions: Waste management rethought. Age of Awareness*. Retrieved February 12, 2022, from <https://medium.com/age-of-awareness/developing-countries-need-new-solutions-waste-management-rethought-8655717d20dd>
- Moghadam, M.A., Mokhtarani, N. and Mokhtarani, B., (2009). Municipal solid waste management in Rasht City, Iran. *Waste Management*, 29(1), pp.485-489.  
(PDF) *Bio-recovery of municipal plastic waste management based on an integrated decision-making framework*. Available from: [https://www.researchgate.net/publication/357717676\\_Bio-recovery\\_of\\_municipal\\_plastic\\_waste\\_management\\_based\\_on\\_an\\_integrated\\_decision-making\\_framework](https://www.researchgate.net/publication/357717676_Bio-recovery_of_municipal_plastic_waste_management_based_on_an_integrated_decision-making_framework) [accessed Feb 12 2022].
- Niessen, W.R. (1977). "Properties of Waste Materials." In: Wilson, D.G., *Handbook of Solid Waste Management*. New York: Van Nostrand Reinhold.
- Papadopoulos, I.; Karagouni, G.; Trigkas, M. and Platogianni, E. (2010). Green Marketing: The Case of Greece in Certified and Sustainable Managed Timber Products, *EuroMed Journal of Business*.
- Reitman, V. (1992), "Green' product sales seem to be wilting", *Wall Street Journal*, 18 May, p. B1.
- Sokona, Y., & Denton, F. (2001). Climate change impacts: Can Africa cope with the challenges? *Climate Policy*, 1(1), 117-123.
- Tchobanoglous, G., H. Theisen, and S. Vigil, (1993). *Integrated Solid Waste Management*. New York: McGrawHill.
- UN General Assembly (2000). United Nations Millennium Declaration, Resolution Adopted by the General Assembly. Sept 18, 2000. A/RES/55/2. <http://www.un.org/millennium/declaration/ares552e.htm>
- Wilson, D. C., Rodic, L., Cowing, M. J., Velis, C. A., Whiteman, A. D., Scheinberg, A., & Oelz, B. (2015). 'Wasteaware' benchmark indicators for integrated sustainable waste management in cities. *Waste Management*, 35, 329-342.
- World Population Review. (n.d.). Bangladesh population 2022 (live). Retrieved February 12, 2022, from <https://worldpopulationreview.com/countries/bangladesh-population>
- Zainudin, A. (2015). "A handbook on SEM: Structural equation modelling," 2nd Edition, Bangi: Universiti Sultan Zainal Abidin, MPWS Publication Sdn. Bhd.

## **AUTHORS' BIOGRAPHY**

**Dr. Mehe Z. Rahman** is the Director of the BBA Program and Associate Professor of Department of Management North South University. She has published many research articles in various peer-reviewed international indexed journals and proceedings of international conferences. She is focused on Sustainable Development and Climate Change and actively involved in women entrepreneurship, SMEs, and development program. She served the instructor of the Training Program Women-Owned Businesses in Bangladesh, supported by World Bank and We Connect International. She is also involved in developing entrepreneurship in Bangladesh, and has been with the City Bank.

**Dr. Farhana Ferdousi** is an Assistant professor of Southeast Business School and Director, Institute of Research & Training (IRT) at Southeast University, Bangladesh. Her research interests are Sustainable Development, Entrepreneurship, Microenterprise, Social Enterprise and Human Resource Management. She has authored several book chapters published from the UK and Croatia. She has also published many research articles in various peer-reviewed international indexed journals and proceedings of international conferences. She is also working as the strategic research partner of Center for Emerging Market Research, Nan Yang University, Singapore and as a consultant with various international projects.

**Shabnin Rahman Shorna** is an academic and currently in the position of Senior Lecturer at Department of Management, School of Business & Economics. And, she is also a Member Secretary of NSU Accreditation Project Team (APT). Besides, Shabnin is one of the course instructors of We Connect Project, City Aloe Women Entrepreneurship Certification Program and City Aloe Rural Development Program. She did her Bachelors (BBA) from North South University and M.Sc. in Entrepreneurship in applied technologies from University of South Florida. Her research interest areas are Entrepreneurship, Strategic Management, Small Business finance, International Business Management etc. Prior entering to academic world, Shabnin used to work in corporate sectors both in home and abroad.

**Tanya Ahmed** is a Lecturer, teaching Management and Business Communication at the School of Business and Economics, North South University, Bangladesh. She received her Masters of Business Administration from one of the top business schools, De La Salle University, Philippines. Her professional experience includes working as a Consultant and Teaching Japanese students. She is also working as a reviewer in an International Journal (IJRISS). Ahmed served as a Faculty Advisor for a cultural club (NSUSS) at North South University and led various cultural programs.